

Electromechanical Fuel Shutoff Valves

MV-94134B
Revised 07-99
Catalog Section 55
(00-02-0124)



Model M5081

M25 and M50 Series

- Instant Response to Shut Off Signal
- Positive Valve Closure
- Vents Gases Trapped After Shutdown
- Explosion-proof Models Available
- Models Available for Magneto, CD Ignition or 12/24 VDC
- Normally Energized Model Available

Description

These fuel shutoff valves are semi-automatic devices for shutdown of natural gas fueled engines. The valve is opened manually and closes when the electromagnet is energized and trips the latch. The valve can be closed manually by turning the valve's disconnect knob. A normally energized model is available that holds the valve open electrically and closes when the coil is de-energized. A vent in the valve body relieves trapped gas when the valve closes. A pop-out indicator button informs you when the valve is open or closed.

The valve's tripping power is provided by an engine ignition system or battery. Models are available for magneto, CD ignition or 12/24 V battery.

The **M2582 is a 1 inch (25 mm) valve** with 1 NPT connections. It has one SPDT snap-switch. The valve body is made of sandcast aluminum. It does not include the open/close indicator button.

M5081 is a 2 inch (51 mm) valve with 2 NPT connections. It has *two* SPDT snap-switches. The valve body is available in sandcast aluminum or cast steel (optional).

M5081FS is the same as the M5081 but has a normally energized circuit. This circuit allows the valve to be held open electrically and close by interruption of the coil's power circuit. **A manual trip knob is not available on this model.** An optional 2 in. (51 mm) steel flange pipe connection is available for M5081 and M5081FS steel body models (see Dimensions page 3).

Specifications

Valve Body: Sandcast aluminum, painted red (corrosion resistance). Optional cast steel available for M5081 and M5081FS models only.

Valve Seat: Buna-N

Maximum Pressure Rating:

- M2582: 80 psig (552 kPa) [5.52 bar]
- M5081: 100 psig (689 kPa) [6.89 bar]
- M5081FS: 100 psig (689 kPa) [6.89 bar]

Coil Rating: Intermittent duty; coil type must match power source;

- CD ignition coil resistance: 72 Ω
CD primary voltage: 1.38 to 3.8 A
- M5081FS model: Energized to run (continuous-duty coil) coil resistance:
12 Volt model: 33 Ω (0.36 A)
24 Volt model: 136 Ω (0.17 A)
- Magneto ignition coil resistance: 0.5 Ω
- Magneto primary voltage: 1 to 5 A
- Battery coil resistance : 7 Ω
12 or 24 VDC: 1.2 to 2.4 A

Wiring (See *Internal Wiring* page 2):

- M2582: *Wire leads*
- M5081 and M5081FS: *Terminal blocks*

Snap-switch Rating: 5 A @ 480 VAC

Laboratory Approval: CSA listed for Class I, Groups C and D Hazardous Locations. 5 amps maximum; intermittent duty; models M5081 and M5081-CD engine ignition powered, and model M5081-B, 12 or 24 VAC or VDC; switch contacts rated 5 A @ 480 VAC maximum.

Options and Accessories

Diode Package (65010065)

The Murphy 202 V diode package is designed to allow the fuel shutoff valve to be used with dual Magneto Ignition systems. Sold separately (see How to Order).

Magnetic Switch Adapter

As ignition systems wear from usage their power output becomes less and less. Ignition may not have the capacity to reliably trip the fuel valve. Therefore, the use of a Magnetic Switch Adapter for *CD ignition systems* is recommended. The adapter stores energy from the CD ignition to trip the fuel valve. Three models are available:

65020126: For Negative Ground CD Ignitions up to 240 VDC

65020127: For Positive Ground CD Ignitions up to 450 VDC

65020155: For Negative Ground CD Ignitions 240 VDC to 450 VDC

Warranty

A limited warranty on materials and workmanship is given with this FW Murphy product. A copy of the warranty may be viewed or printed by going to www.fwmurphy.com/support/warranty.htm

Flow Rates

M2582

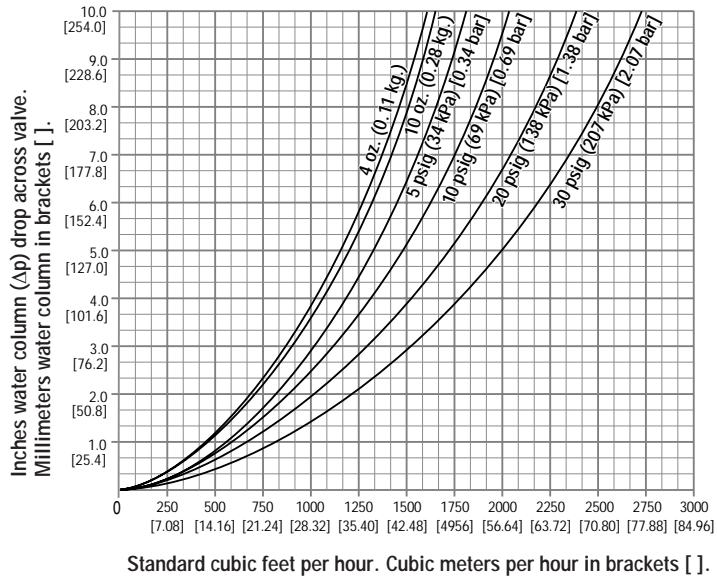

Internal Wiring

M2582

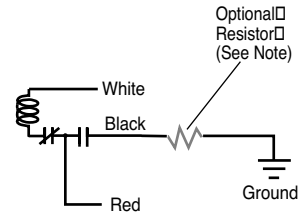

NOTE: For grounding the ignition (CD models only) through the fuel valve's internal snap-switch, a Murphy Magnetic Switch adapter (see page 4) must be used in addition to a 100 ohm, 2 watt resistor (supplied with valve).

M5081 and M5081FS

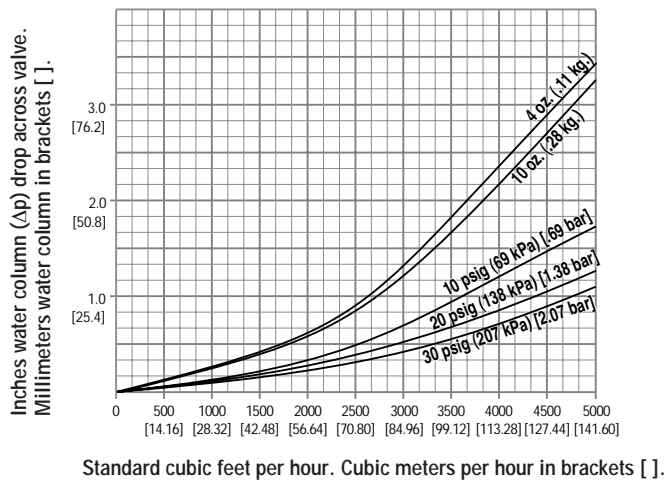

M5081 and M5081FS

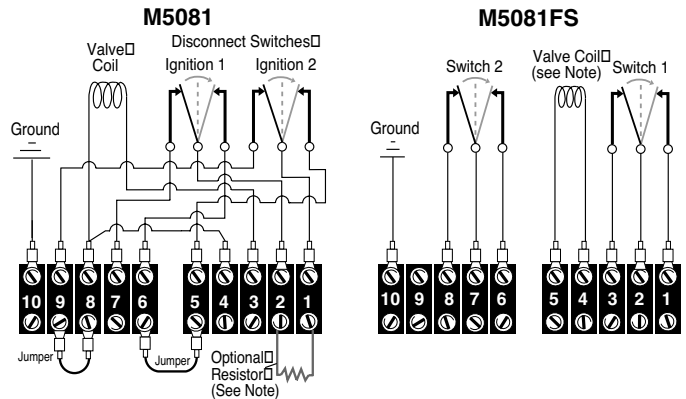

NOTE: For grounding the ignition (CD models only) through the fuel valve's internal snap-switch, a Murphy Magnetic Switch adapter (see page 4) must be used in addition to a 100 ohm, 2 watt resistor (supplied with valve).

Dimensions

M2582

Steel Flanged Option "3"
(available on M5081 and M5081FS steel body configurations only)

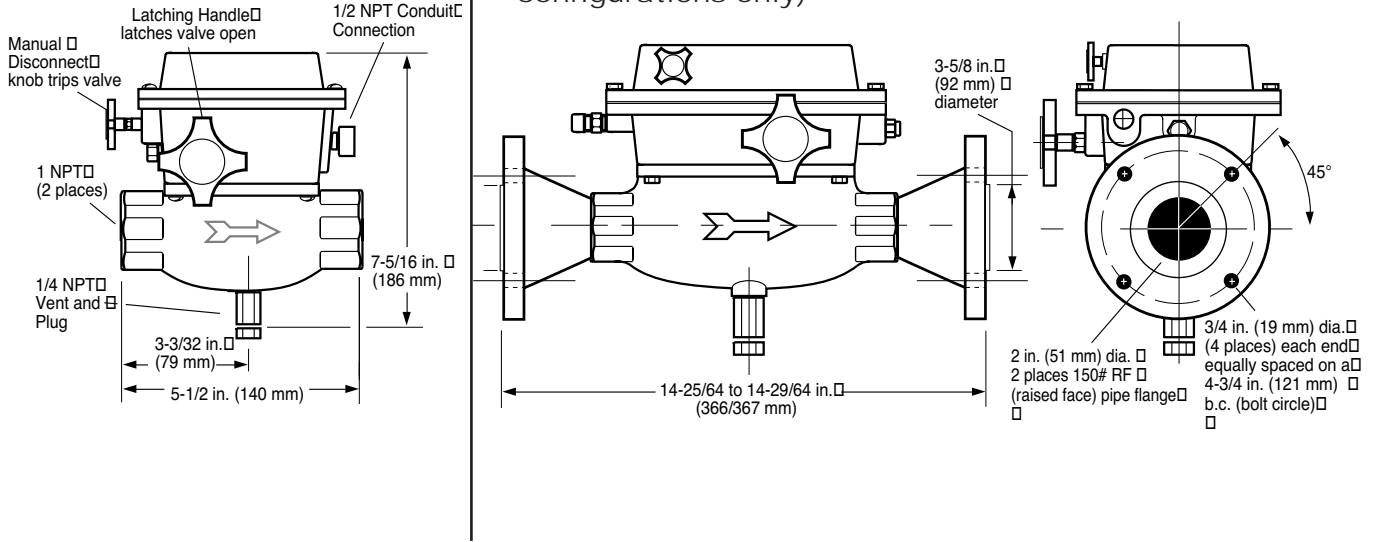

M5081 and M5081FS

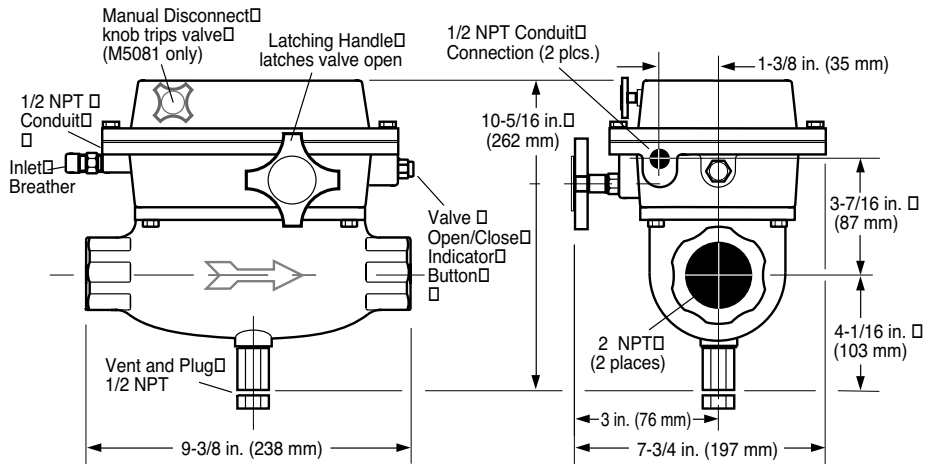

How to Order

To order your valve, use the diagram below to specify your model and options.

Example: **M5081-A-2**

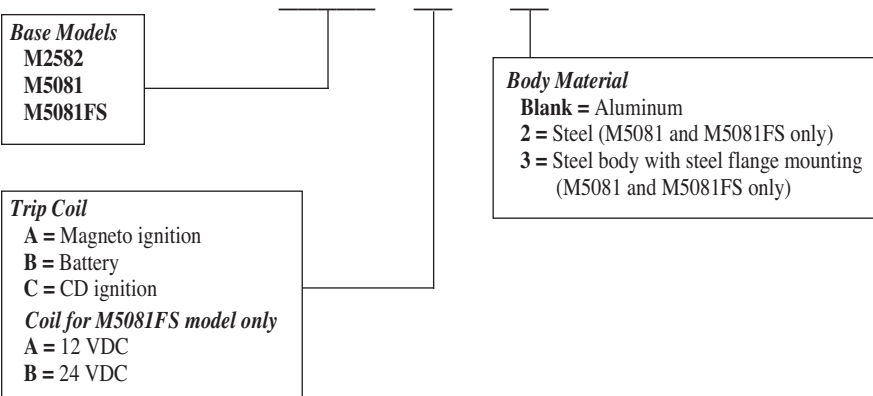

Accessories

Specify part number when ordering.

Magnetic Switch Adapter

65020126: For Negative Ground CD Ignitions up to 240 VDC

65020127: For Positive Ground CD Ignitions up to 450 VDC

65020155: For Negative Ground CD Ignitions 240 VDC to 450 VDC

Diode Package

65010065: For use with dual Magneto Ignition systems.

Shipping Information

Shipping Weights:

- M2582: 5 lbs 8 oz. (2.49 kg)
- M5081: 14 lbs 8 oz. (6.58 kg)
- M5081-2: 40 lbs (18.14 kg)
- M5081-3: 56 lbs (25.40 kg)
- M5081FS: 14 lbs 8 oz. (6.58 kg)
- M5081FS-2: 40 lbs (18.14 kg)
- M5081FS-3: 56 lbs (25.40 kg)

Shipping Dimensions:

- M2582: 8 x 8 x 7 in. (203 x 203 x 178 mm)
- M5081: 12 x 12 x 9-5/16 in. (305 x 305 x 237 mm)
- M5081-2: 12 x 12 x 9-5/16 in. (305 x 305 x 237 mm)
- M5081-3: 18 x 12 x 13-1/2 in. (457 x 305 x 343 mm)
- M5081FS: 12 x 12 x 9-5/16 in. (305 x 305 x 237 mm)
- M5081FS-2: 12 x 12 x 9-5/16 in. (305 x 305 x 237 mm)
- M5081FS-3: 18 x 12 x 13-1/2 in. (457 x 305 x 343 mm)

Service Parts

Specify part number when ordering.

	M2582	M5081	M5081FS
Coil Assembly			
Battery	55000128	55000126	—
CD Ignition	55000129	55000127	—
Magneto Ignition	55000094	55000080	—
"FS" Coil Assembly			
12 VDC	—	—	55000158
24 VDC	—	—	55000159
Latch Block Assembly			
Latch block assembly	55000095	55000074	—
Latch block switch and coil assembly	55000144	—	—
Latch block switch and mounting bracket assembly	—	55000118	—
Handle and Latch Kit			
Handle and latch kit	—	55000102	55000102
Handle kit	55000096	—	—
Manual Disconnect Assembly			
Manual Disconnect Assembly	55000097	55000137	—
Snap-switch Assembly			
Snap-switch Assembly	55000098	55000072	55000160
Close/Open Indicator Assembly			
Close/Open Indicator Assembly	—	5500-0138	55000138
Stem and Seat Kit			
Stem and Seat Kit	55000093	55000075	55000135
Top Works Complete Valve Less Body and Vent			
Top Works Complete Valve Less Body and Vent	55000146	55000131	55000161 (12V) 55000194 (24V)
Vent Bushing Assembly			
Vent Bushing Assembly	55000143	55000132	55000132
Diaphragm Assembly			
Diaphragm Assembly	—	—	—
Pilot Diaphragm			
Pilot Diaphragm	—	—	—
Diode Package for Dual Magneto Ignitions			
Diode Package for Dual Magneto Ignitions	—	65010065	—
Magnetic Switch Adapter for CD Ignitions			
Single/Dual ign. – negative ground up to 240 VDC	65020126	65020126	—
Single/Dual ign. – positive ground up to 450 VDC	65020127	65020127	—
Single/Dual ign. – negative ground up to 450 VDC	65020155	65020155	—

FW MURPHY

P.O. Box 470248
Tulsa, Oklahoma 74147 USA
+1 918 317 4100 Fax: +1 918 317 4266
E-mail: sales@fwmurphy.com

INDUSTRIAL PANEL DIVISION

Fax: +1 918 317 4124
E-mail: ipdsales@fwmurphy.com

MURPHY POWER IGNITION

Web site: www.murphy-pi.com

www.fwmurphy.com

CONTROL SYSTEMS & SERVICES DIVISION

P.O. Box 1819
Rosenberg, Texas 77471 USA
Phone: +1 281 633 4500 Fax: +1 281 633 4588
E-mail: sales@fwmurphy.com

FRANK W. MURPHY, LTD

Church Rd Laverstock
Salisbury SP1 1OZ UK
Phone: +44 172 241 0055 Fax: +44 172 241 0088
E-mail: sales@fwmurphy.co.uk
Web site: www.fwmurphy.co.uk

COMPUTRONIC CONTROLS, LTD

41 - 43 Railway Terrace Nechells
Birmingham B7 5NG UK
Phone: +44 121 327 8500 Fax: +44 121 327 8501
E-mail: info@computroniccontrols.com
Web site: www.computroniccontrols.com

FW MURPHY INSTRUMENTS (HANGZHOU) CO. LTD

77 23rd Street
Hangzhou Economic & Technological Development Area
Hangzhou, Zhejiang 310018 China
Phone: +86 571 8788 6060 Fax: +86 571 8684 8878



Printed in U.S.A.