

WCSB Description

Section D

The WCSB is a disc-type, water-cooled and air-cooled unit. These units provide dynamic tensioning, static holding and emergency stopping removing the need for multiple braking systems.

The WCSB incorporates water-cooled and air-cooled friction discs within one brake that is pressure-applied and spring-applied. The pressure-applied side is used for dynamic tensioning. The spring-applied side is used for emergency stopping and holding.

Pressurizing the air-applied side causes the piston to clamp the water-cooled friction discs between the water-jackets. Immediately following pressurization of the air-applied side, air pressure must be applied to release the spring-applied side. Applying air to the spring-applied side pushes the spring-applied cylinder back and releases the air-cooled friction disc. This will ensure that the load does not free-fall.

Once the spring-applied side is fully released, air pressure is slowly released from the large and small pistons on the air-applied side until the load begins to move. Releasing air-pressure from the spring-applied side causes the cylinder to move forward, clamping down on both the air-cooled and water-cooled friction discs during an emergency stop or for static holding.

The air-applied piston incorporates a small and large piston. The small piston can be used to provide an air pressure that can be managed by standard regulators which increases controllability during the tensioning mode with light loads.

Element sizes are indicated by the number of water-cooled friction discs, the number of air-cooled friction discs and the disc diameter in inches. For instance, the 324WCSB 2W/1A has 3 friction discs. Two of the friction discs are water-cooled and one of the friction discs is air-cooled. The diameter of the water-cooled friction discs is 24 inches.



Features:

Combination Power Packs

Dynamic tensioning, static holding and emergency stopping are provided by one brake removing the need for multiple braking systems.

Dual Air-Applied Pistons

Dual air-applied pistons provide greater controllability with a varying range of loads.

Torque and Horsepower Independent of Rotational Speed

Torque can be obtained at all speeds and the WCSB can withstand high thermal power loading throughout the tensioning cycle.

Unique Friction Couple

A specially formulated friction material, interfacing with a copper alloy surface, eliminates the stick-slip characteristics associated with ordinary frictional devices.

Optional Corrosion Resistance Package

For marine environments, protective coatings are available to minimize corrosion.

Where used:

- Drawworks
- Mooring Systems
- Log Yarders

WCSB Component Parts

Section D

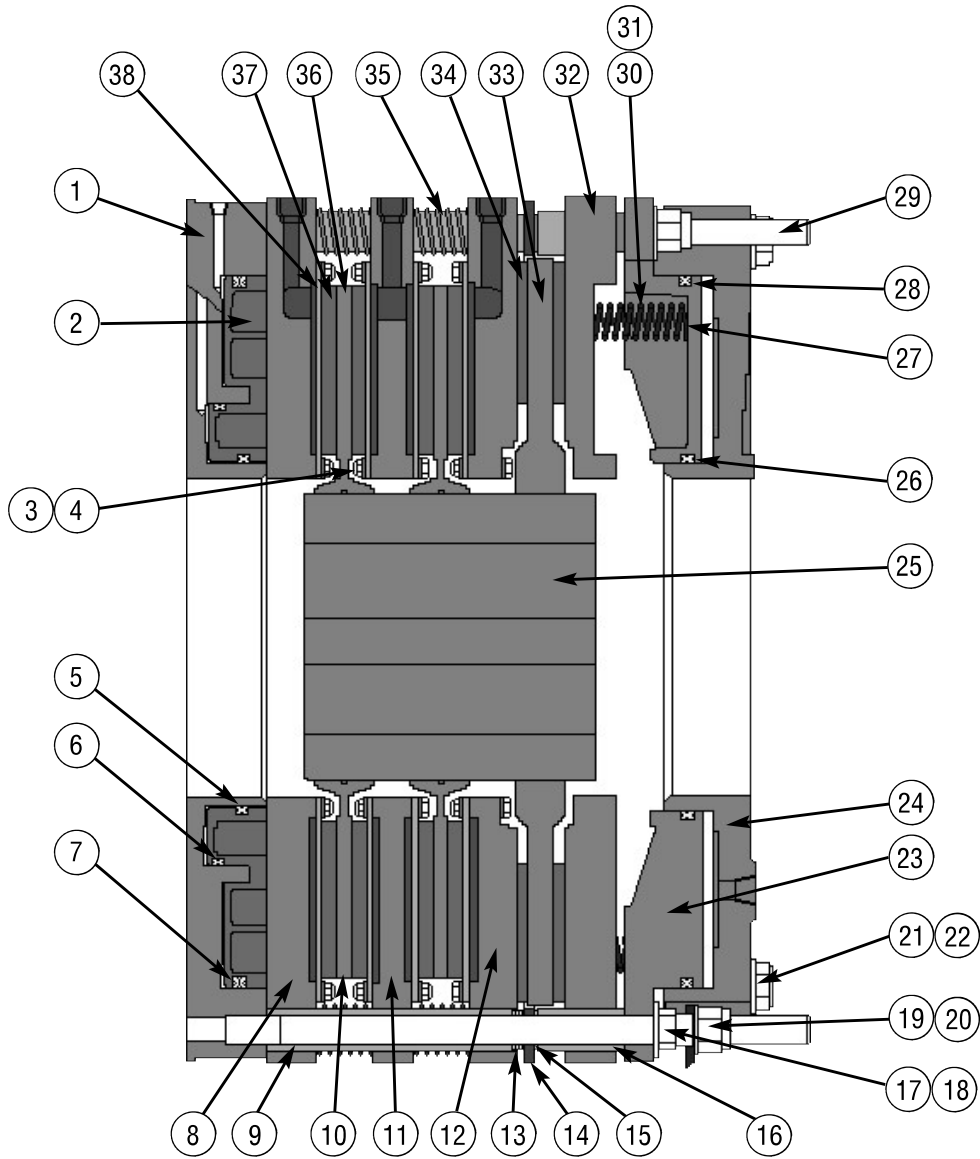

Item	Description
1	Mounting Flange/Cylinder
2	Air-Applied Piston
3	Hex Head Screw
4	Locknut
5	Air-Applied Inner Seal
6	Air-Applied Intermediate Seal
7	Air-Applied Outer Seal
8	Water-Cooled Pressure Plate
9	Clamp Tube
10	Water-Cooled Friction Disc Assembly
11	Reaction Plate
12	End Plate
13	Wear Spacers
14	Stop Plate
15	Wear Spacer
16	Clamp Tube
17	Sleeve Nut
18	Flat Washer
19	Self Locking Nut

Item	Description
20	Flat Washer
21	Hex Head Screw
22	Flat Washer
23	Spring Housing
24	Cylinder
25	Gear
26	Spring-Applied Inner Seal
27	Spring Retainer
28	Spring-Applied Outer Seal
29	Stud
30	Inner Spring
31	Outer Spring
32	Spring-Applied Pressure Plate
33	Air-Cooled Solid Disc
34	Air-Cooled Friction Disc
35	Release Spring
36	Water-Cooled Friction Disc Core
37	Water-Cooled Friction Disc
38	Wear Plate

Note:

- ❶ The above cross-section shows a unit with two water-cooled friction disc assemblies. For units with one water-cooled friction disc assembly, item 11 is not required.

WCSB Elements - Dimensional Data*

Section D

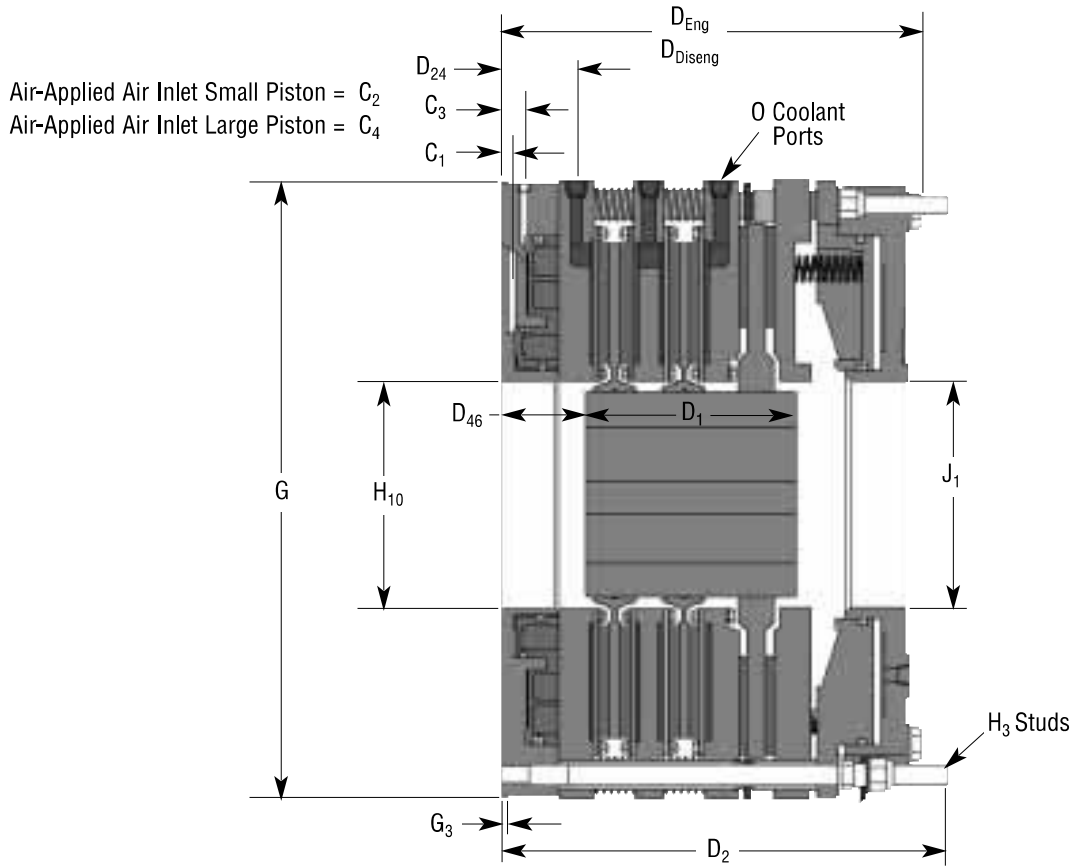

Mounting Bolt Circles ①

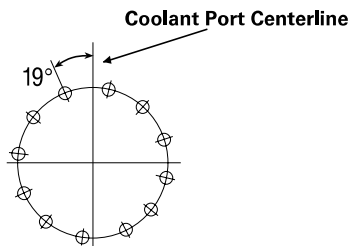

Pressure Plate Coolant Inlet Port
24WCSB
 12-0.656 (16,7) Dia. Holes Equally Spaced Holes on a 28.750" (730,3) BC

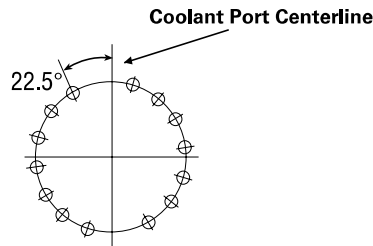

Pressure Plate Coolant Inlet Port
36WCSB
 14-1.062 (27,0) Dia. Holes based on 16 Equally Spaced Holes on a 42.000" (1066,8) BC

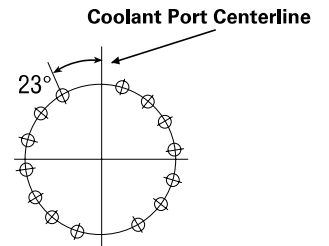

Pressure Plate Coolant Inlet Port
48WCSB
 14-1.438 (36,5) Dia. Holes based on 16 Equally Spaced Holes on a 54.000" (1371,6) BC

* Data shown is subject to change. Please consult factory for current dimensional data.

English	Dimensions in inches														
24WCSB	.87	1/4-18	1.28	1/2-14	4.00	3.63	29.998	.125	11.38	11.50	12	1 1/8 - 7	27.875	1/2-14 NPT	18.500
36WCSB	.99	3/8-18	1.50	3/4-14	5.31	6.00	44.498	.250	16.50	16.50	16	1 3/8 - 6	41.500	3/4-14 NPT	28.000
48WCSB	1.17	1/2-14	1.80	1-11 1/2	5.94	6.75	56.499	.250	23.00	23.00	16	1 3/8 - 6	53.688	1-11 1/2 NPT	41.500

Size	C ₁	C ₂	C ₃	C ₄	D ₂₄	① D ₄₆	② G	G ₃	H ₁₀	J ₁	No.	Size	Bolt Circle	Size	Bolt Circle		
											No.	Size	Bolt Circle	③ H ₃		④ O ₂	
														Size	Bolt Circle	Size	Bolt Circle
24WCSB	22,1	1/4-18	32,5	1/2-14	101,6	92,2	761,9	3,2	289,1	292,1	12	1 1/8-7	708,0	1/2-14 NPT	469,9		
36WCSB	25,1	3/8-18	38,1	3/4-14	134,9	152,4	1130,1	6,4	419,1	419,1	16	1 3/8-6	1054,1	3/4-14 NPT	711,2		
48WCSB	29,7	1/2-14	45,7	1-11 1/2	150,9	171,5	1435,1	6,4	584,2	584,2	16	1 3/8-6	1363,7	1-11 1/2 NPT	1054,1		

SI	Dimensions in millimeters														
----	---------------------------	--	--	--	--	--	--	--	--	--	--	--	--	--	--

WCSB Elements

Dimensional Data*

Section D

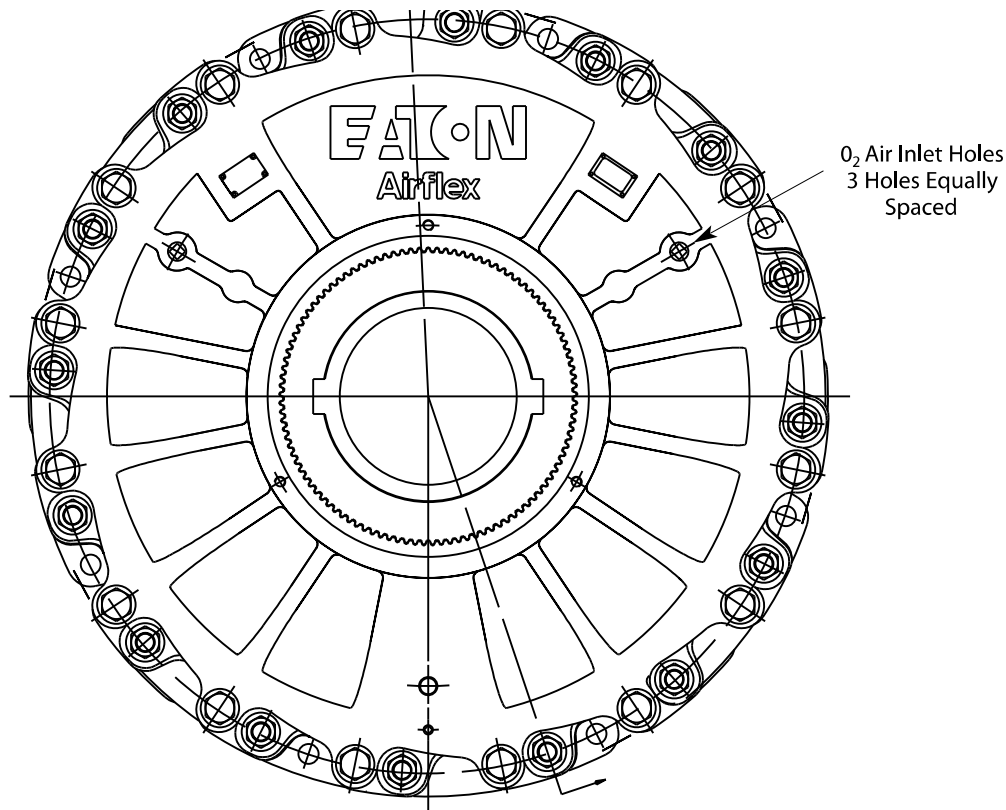

English		Dimensions in inches						
224WCSB 1W/1A	8.63	17.44	18.59	18.77	4	3/4 SAE ORB	6.125	8.250
324WCSB 2W/1A	13.19	21.94	22.45	22.72	8	3/4 SAE ORB	7.000	8.250
424WCSB 3W/1A	16.94	28.19	26.50	26.86	12	3/4 SAE ORB	7.750	8.000
236WCSB 1W/1A	10.00	22.81	24.69	25.01	4	1 1/4 SAE ORB	8.875	11.500
336WCSB 2W/1A	14.00	28.81	29.54	29.87	8	1 1/4 SAE ORB	10.250	11.250
436WCSB 3W/1A	19.50	36.31	34.40	34.81	12	1 1/4 SAE ORB	11.250	11.375
248WCSB 1W/1A	11.25	27.46	30.55	30.86	4	1 1/4 SAE ORB	11.375	16.250
348WCSB 2W/1A	16.75	34.21	36.05	36.51	8	1 1/4 SAE ORB	13.000	16.250
448WCSB 3W/1A	22.50	41.46	41.54	42.16	12	1 1/4 SAE ORB	14.375	16.250
Size	D ₁	D ₂	D _{Eng}	D _{Diseng}	No.	Size	Min.	Max.
					O Coolant Ports ⑤		Bore Range	
					No.	Size	Min.	Max.
224WCSB 1W/1A	219,2	443,0	472,2	476,8	4	3/4 SAE ORB	155,6	209,6
324WCSB 2W/1A	335,0	557,0	570,2	577,1	8	3/4 SAE ORB	77,8	209,6
424WCSB 3W/1A	430,3	716,0	673,1	682,2	12	3/4 SAE ORB	196,9	203,2
236WCSB 1W/1A	254,0	579,4	627,1	635,3	4	1 1/4 SAE ORB	225,4	292,1
336WCSB 2W/1A	355,6	731,8	750,3	758,7	8	1 1/4 SAE ORB	260,4	285,8
436WCSB 3W/1A	495,3	922,3	873,8	884,2	12	1 1/4 SAE ORB	285,8	288,9
248WCSB 1W/1A	285,8	697,5	776,0	783,8	4	1 1/4 SAE ORB	288,9	412,8
348WCSB 2W/1A	425,5	868,9	915,7	927,4	8	1 1/4 SAE ORB	330,2	412,8
448WCSB 3W/1A	571,5	1053,1	1055,1	1070,9	12	1 1/4 SAE ORB	365,1	412,8
SI		Dimensions in millimeters						

Note:

- ① To insure proper cooling, inlet port must be located at the six o'clock position.
- ② Tolerance for the 24WCSB is +0.000/-0.003 (+0,000/-0,08). Tolerance for the 36WCSB and the 48WCSB is +0.000/-0.005 (+0,000/-0,13).
- ③ American National Standard for Unified Screw Threads.
- ④ American National Pipe Thread.
- ⑤ Water-cooled pressure plate and end plate have single inlet and outlet cooling ports. Reaction plates have dual inlet and outlet cooling ports
- ⑥ Tolerance +/-0.030 (+/-0,76).

* Data shown is subject to change. Please consult factory for current dimensional data.

WCSB Elements

Technical Data*

Section D

English			lb-in. @ 80 psi			lb-in	lb-in. @ 120 psi		HP
224WCSB 1W/1A	146452C	410970	43470	117530	161000	351000	378000	392000	270
324WCSB 2W/1A	146453C	412433	86940	235060	322000	523000	505000	620000	540
424WCSB 3W/1A	146454C	413195	130680	353320	484000	676000	617000	844000	810
236WCSB 1W/1A	146436C	416821	111120	351880	463000	1086000	1330000	1218000	650
336WCSB 2W/1A	146477C	416842	222240	703760	926000	1558000	1747000	1872000	1300
436WCSB 3W/1A	146402C	416676	333360	1055640	1389000	1969000	2107000	2514000	1950
248WCSB 1W/1A	146478C	416795	245180	697820	943000	2526000	2518000	2907000	1300
348WCSB 2W/1A	146400C	416688	490360	1395640	1886000	3335000	3372000	4239000	2600
448WCSB 3W/1A	146479C	416797	735800	2094200	2830000	3976000	4052000	5548000	3900
Size	① Part Number	Gear Part Number	Small Piston	Large Piston	Both Pistons	② Spring Applied Dynamic Torque	② Spring Applied Static Torque	⑤ Maximum Dynamic Torque	④ Thermal Rating
			Air-Applied Dynamic Torque ③						
			Small Piston	Large Piston	Both Pistons				
224WCSB 1W/1A	146452C	410970	4908	13269	18177	39628	42676	44257	201,3
324WCSB 2W/1A	146453C	412433	9816	26538	36354	59047	57015	69998	402,7
424WCSB 3W/1A	146454C	413195	14754	39890	54644	76320	69659	95288	604,0
236WCSB 1W/1A	146436C	416821	12545	39727	52273	122609	150157	137512	484,7
336WCSB 2W/1A	146477C	416842	25091	79455	104545	175898	197236	211349	969,4
436WCSB 3W/1A	146402C	416676	37636	119182	156818	222300	237880	283831	1454,1
248WCSB 1W/1A	146478C	416795	27681	78784	106465	285185	284282	328200	969,4
348WCSB 2W/1A	146400C	416688	55362	157568	212929	376522	380699	478583	1938,8
448WCSB 3W/1A	146479C	416797	83072	236435	319507	448890	457471	626369	2908,2
SI			Nm @ 5,5 bar			Nm	Nm @ 10,3 bar		kW

Notes:

- ① Basic part number only. Gear must be ordered separately.
- ② Torque is based on a spring set release pressure of 120 psi and the maximum amount of apply springs. To decrease release pressure, springs can be removed. The maximum number of springs for each size are as follows: 24WCSB – 48 (24 outer springs and 24 inner springs), 36WCSB – 128 (64 outer springs and 64 inner springs), 48WCSB – 112 springs.
- ③ Exact torque rating is dependent upon applied pressure. Maximum allowable air-applied pressure is 150 psi
- ④ Based upon a 70° F (21° C) fresh water inlet temperature and a 50° F (28° C) temperature rise between inlet and outlet. See cooling requirements.
- ⑤ Maximum torque results when 120 psi is applied to the air-applied side and the spring-applied side is fully set simultaneously. If air pressure is lost, the torque will drop to the spring-applied static torque.

WCSB Elements

Technical Data

Section D

English	PSI			GPM			in ³		rpm		in ³	
224WCSB 1W/1A	17	6	5	27	4.30E-03	1.20E-01	160	136	715	1200	73	159
324WCSB 2W/1A	18	7	6	54	1.10E-03	6.10E-02	320	272	715	1200	104	190
424WCSB 3W/1A	19	8	7	81	4.80E-04	4.10E-02	480	408	715	1200	135	221
236WCSBEP 1W/1A	18	6	5	78	1.20E-03	8.90E-02	600	308	475	700	220	424
336WCSBEP 2W/1A	19	7	6	156	2.80E-04	5.80E-02	1135	616	475	700	318	522
436WCSBEP 3W/1A	20	8	7	234	1.20E-04	3.90E-02	1670	924	475	700	416	620
248WCSB 1W/1A	17	6	5	130	1.10E-03	4.60E-02	700	546	360	600	467	821
348WCSB 2W/1A	18	7	6	260	2.30E-04	3.60E-02	1400	1091	360	600	679	1033
448WCSB 3W/1A	19	8	7	390	1.00E-04	2.40E-02	2100	1637	360	600	891	1245
Size	Small	Large	Both	Water Flow [®]	C ₁ Pressure Coefficient	C ₂ Drop [®] Coefficient	Water Volume	WC Lining Wear Volume	Maximum [®] Slip Speed	Maximum [®] Freewheeling Speed	New Air Engaging Volume	Worn [®] Volume
224WCSB 1W/1A	1,17	0,41	0,34	102,2	2,1E-05	2,2E-03	2,6	2,2	715	1200	1,2	2,6
324WCSB 2W/1A	1,24	0,48	0,41	204,4	5,2E-06	1,1E-03	5,3	4,5	715	1200	1,7	3,1
424WCSB 3W/1A	1,31	0,55	0,48	307,0	2,3E-06	7,4E-04	7,9	6,7	715	1200	2,2	3,6
236WCSBEP 1W/1A	1,24	0,41	0,34	295,3	5,7E-06	1,6E-03	9,8	5,0	475	700	3,6	6,9
336WCSBEP 2W/1A	1,31	0,48	0,41	590,5	1,3E-06	1,1E-03	18,6	10,1	475	700	5,2	8,6
436WCSBEP 3W/1A	1,38	0,55	0,48	885,8	5,9E-07	7,1E-04	27,4	15,1	475	700	6,8	10,2
248WCSB 1W/1A	1,17	0,41	0,34	492,1	5,2E-06	8,4E-04	11,5	8,9	360	600	7,7	13,5
348WCSB 2W/1A	1,24	0,48	0,41	984,2	1,1E-06	6,5E-04	22,9	17,9	360	600	11,1	16,9
448WCSB 3W/1A	1,31	0,55	0,48	1476,3	4,8E-07	4,4E-04	34,4	26,8	360	600	14,6	20,4
SI	bar			dm ³ /min			dm ³	rpm		dm ³		

English	in ³	lb-ft ²	lb		in	
224WCSB 1W/1A	259	140	1260	363	8.71	7.90
324WCSB 2W/1A	259	216	1448	561	10.81	9.98
424WCSB 3W/1A	259	291	1641	745	12.96	11.89
236WCSBEP 1W/1A	612	919	4466	873	12.54	11.34
336WCSBEP 2W/1A	612	1284	5026	1227	14.92	13.76
436WCSBEP 3W/1A	612	1659	5954	1615	17.78	16.33
248WCSB 1W/1A	1115	3128	7869	1689	15.15	12.60
348WCSB 2W/1A	1115	4603	9189	2480	18.03	15.33
448WCSB 3W/1A	1115	6086	10521	3283	20.89	18.11
Size	Spring-Applied Release Volume	Wk ² Disc & Gear J	Weight Housing Mass	Disc & Gear	Center of Gravity [®] Housing Center of Gravity	
224WCSB 1W/1A	4,2	5,9	572	165	221,2	200,7
324WCSB 2W/1A	4,2	9,1	657	254	274,6	253,5
424WCSB 3W/1A	4,2	12,3	744	338	329,2	302,0
236WCSBEP 1W/1A	10,0	38,7	2026	396	318,5	288,0
336WCSBEP 2W/1A	10,0	54,1	2280	557	379,0	349,5
436WCSBEP 3W/1A	10,0	69,9	2701	733	451,6	414,8
248WCSB 1W/1A	18,3	131,8	3569	766	384,8	320,0
348WCSB 2W/1A	18,3	194,0	4168	1125	458,0	389,4
448WCSB 3W/1A	18,3	256,5	4772	1489	530,6	460,0
SI	dm ³	kg-m ²	kg		mm	

Notes:

- Absolute volume of cylinder at contact with new and worn friction discs. Worn volume assumes one wear spacer thickness of wear.
 - Coefficients are based on the maximum pressure drop across the individual water cavities of the brake.
 - To insure proper cooling, the inlet port must be at the six o'clock position.
 - Located from the mounting flange surface.
 - Based upon a continuous slip velocity of 4500 fpm (22,9 mps).
 - Maximum freewheeling velocity is 7500 fpm (38,1 mps).
- * Data shown is subject to change. Please consult factory for current dimensional data.